



PRODUCT LINE

Overview

About Us	02
Product Comparison Charts	04
Full Range	05
Woofers	11
Tweeters	22
Professional Woofers & Full Range	29
Professional Tweeters & Compression Drivers	33
Power Amplifier Modules	35
Specialty Applications	37

Why Peerless

World-Class Partner

Since 1926, Peerless has been setting the standard in loudspeaker design and technology. We leverage our global scale and buying power to provide high-performance, affordable solutions across the board.

Use Our Integration Expertise

As a supplier to the world's leading audio brands, we understand your needs and system integration requirements at a key component level. Behind every one of our loudspeakers and amplifiers is a team dedicated to providing you with more options for your designs.

Performance Through Testing

With over 700 R&D engineers in our group, we design, test, and optimize to industry-leading standards. Our advanced validation process ensures our products perform time after time.

Our expertise, scale, and performance make us the best partner for your brand.



Our Expertise Off the Shelf

Drivers Designed for Consistency and Performance

Over 1200 designs are available in our portfolio for a wide variety of applications. Our drivers are built for reliability and quality, delivering maximum performance for your targeted price points.

Amps Built for Flexible Configuration

With optimized power supply and flexible channel configurations, our amplifier modules provide the best options for your system designs. Peerless amplifiers are certified, robust, and offer excellent value.



Discover What You Need

COLOR KEY



TWEETERS

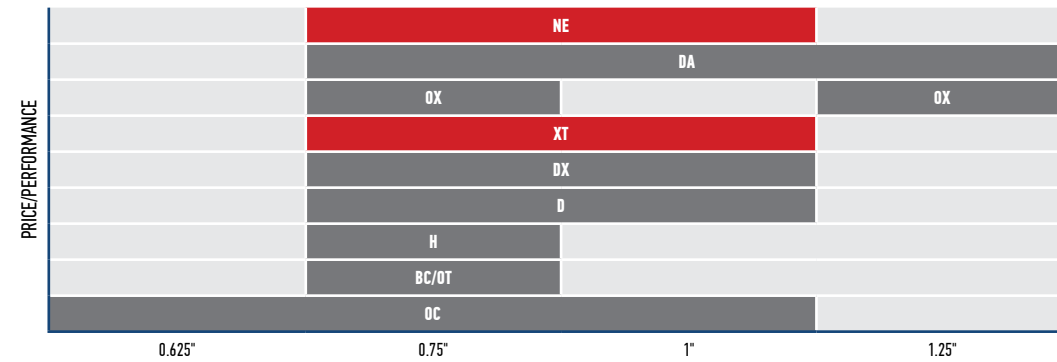

COMPRESSION DRIVERS

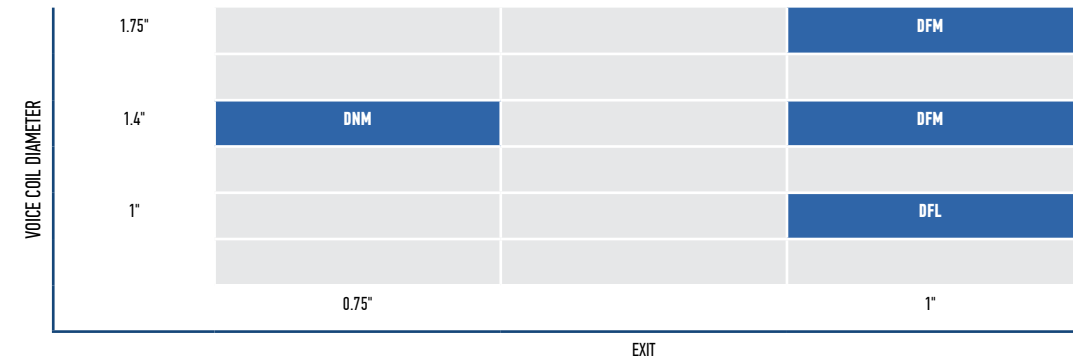

WOOFERS

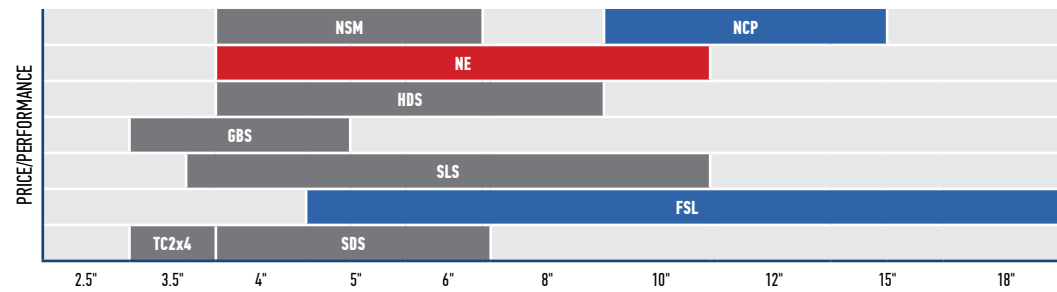

FULL RANGE AND COAXIAL

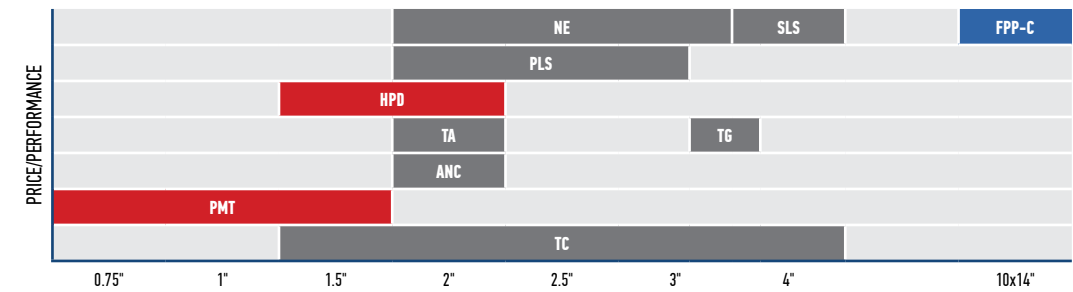

SUBWOOFERS

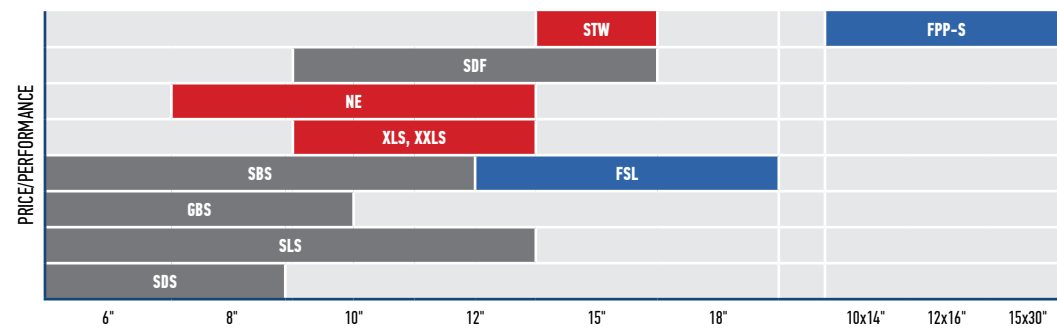

AMPLIFIER MODULES

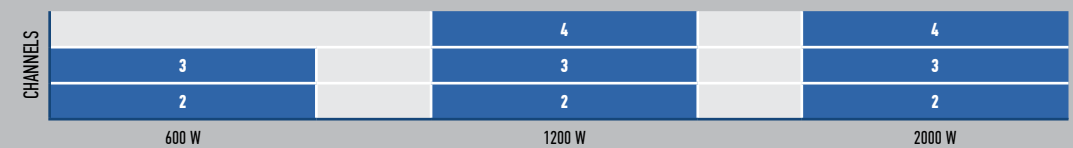

PLS

Full Range



SIZE:
2", 2.5", & 3"



DIAPHRAGM:
ALUMINUM



MOTOR:
NEODYMIUM OR
FERRITE

We designed PLS drivers with unique design and material enhancements that make these full-range drivers perfect for both consumer and professional audio applications. The series was designed for low distortion at low frequencies, extended high frequency response, and advanced motor cooling. PLS drivers are ideal for space-constrained applications where a high-quality, full-range driver is needed, such as compact music systems, TV sound bars, and professional line arrays.



PLS

Technical Highlights

We designed PLS drivers with unique design and material enhancements that make these full-range drivers perfect for both consumer and professional audio applications. From the 1" voice coil to the advanced motor cooling system, every component is fully optimized for high-performance at competitive costs.

Design Enhancements

1" voice coil – For the neodymium versions of PLS, the relatively large winding width and large diameter of the voice coil allow for more magnet in the middle – enabling more excursion, higher BL, and higher power handling.

Advanced Motor Cooling – PLS utilizes a thermal path with a vented basket under the spider for better airflow through the motor system – this further enables better power handling.

Suspension System Design – The spider and surround are designed such that the excursion limits are matched. The subtle elliptical surround helps us achieve better control over the shape of the compliance curve. By matching the height of the surround to elliptical shape, we can fine-tune the flatness of the compliance curve.

Material Enhancements

Copper Cap – The copper cap is extended further than a conventional full-range driver, which provides better inductance symmetry and reduces the distortion by changing inductance. It also extends the high frequency response of the driver due to the lower inductance.

Packing Density – The frame is designed such that the surround goes almost to the edge of the frame. This makes the driver mechanically ideal for a line array.

Suspension Stiffness: PLS-65F25AL00-08

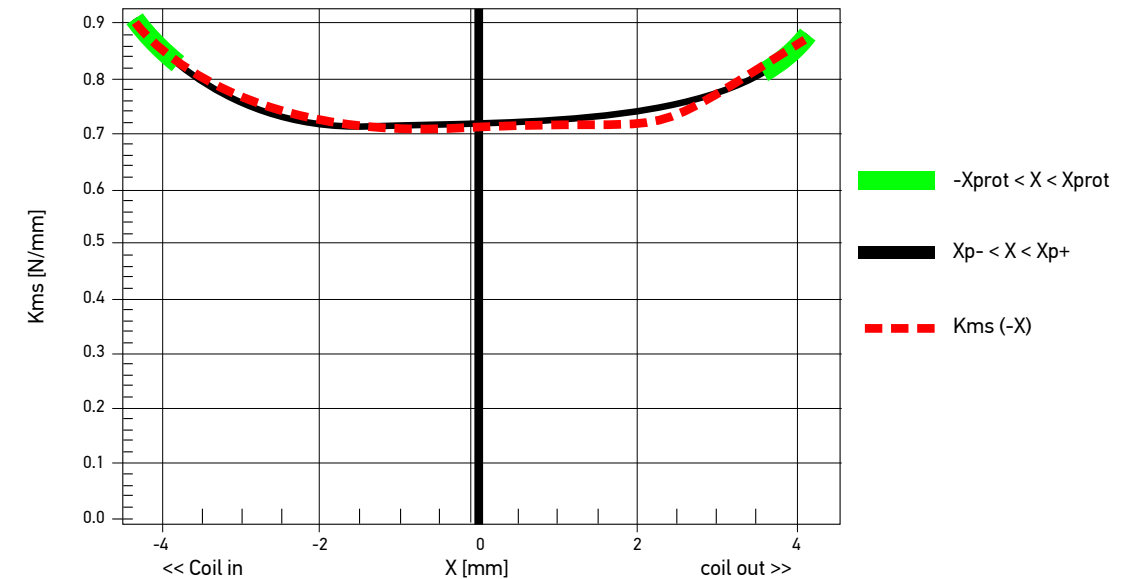

Magnet Simulation: PLS-75N25AL02-08

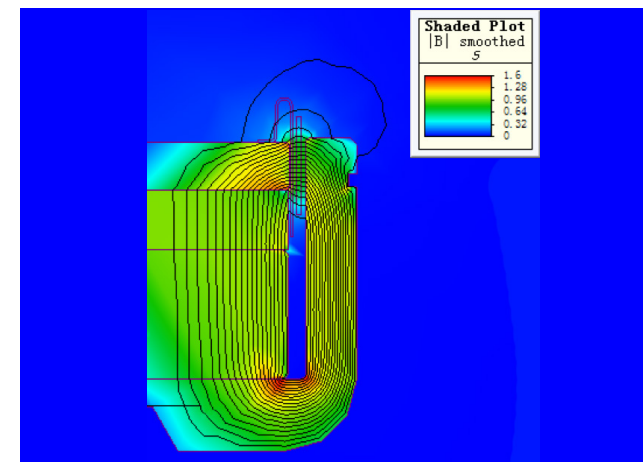

PMT

Micro Full Range

SIZE:
18mm – 40mm

DIAPHRAGM:
ALUMINUM

MOTOR:
NEODYMIUM

These full-range drivers are optimized for big sound from a small footprint, with a spiderless suspension system and large excursion. Added ferrofluid enhances power handling and provides robust centering for the most demanding applications. PMT drivers are designed for a variety of miniature applications such as ultra-compact music speakers, teleconference systems, pro line arrays, and devices requiring intelligible voice interfaces.



[Return to Table of Contents](#)

PMT

Technical Highlights

Optimized for applications where mounting depth is scarce – PMT is our series of micro full-range drivers. Applications include communications devices, high-performance AR/VR, notebooks, and connected devices.

Big Sound from a Small Footprint

High-volume displacement capability of our PMT drivers enables high-maximum, low frequency output, while the utilization of ferrofluid in the gap provides centering capability for the voice coil. The ferrofluid is retained between the top plate inside the voice coil, creating a sleeve where the coil will ride and be centered. Additionally, this fluid prevents the voice coil from rubbing and buzzing.

Frequency & Impedance Response: PMT-20N12AL04-04

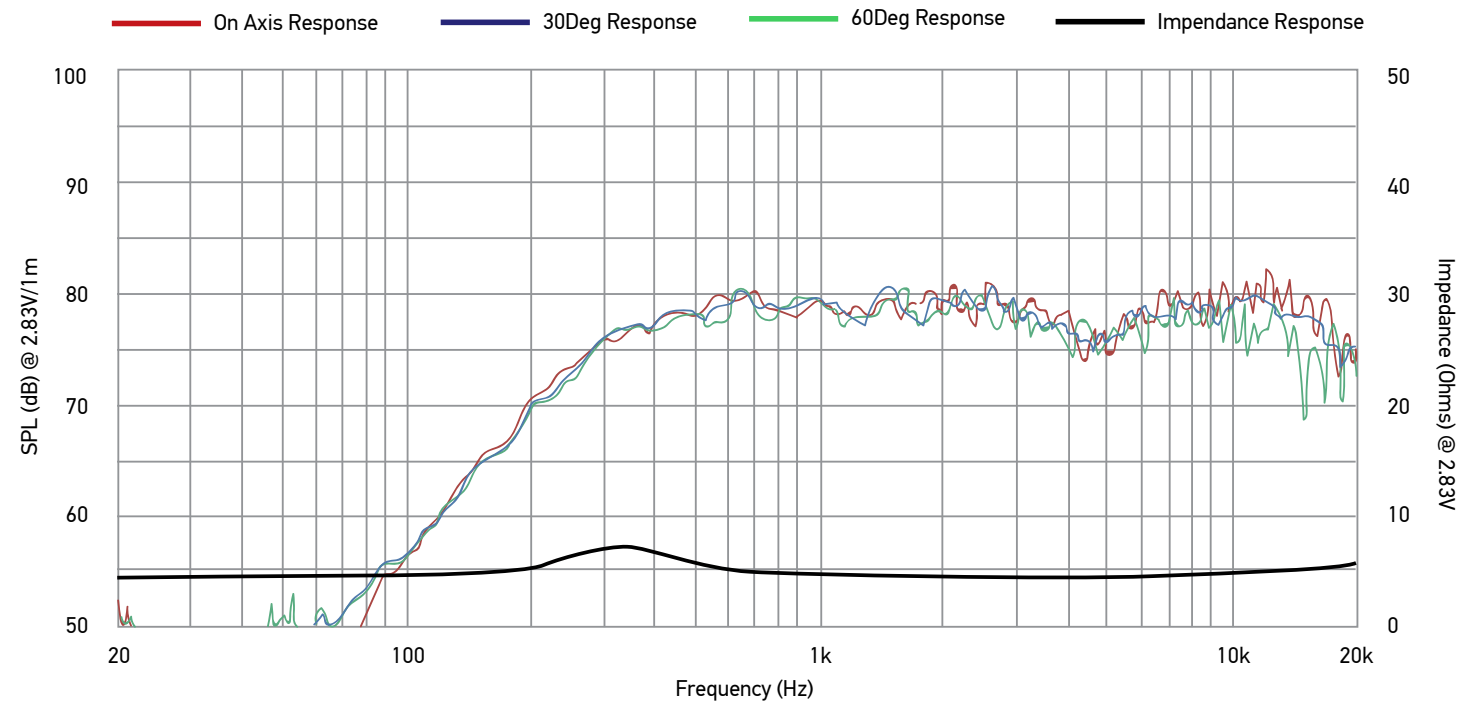

Fully Optimized Micro Full-Range Drivers

Like all Peerless by Tympany drivers, each PMT model is fully optimized for the best performance-to-price ratio on the market. PMT series drivers are built with an aluminum cone, which provides extended frequency response and heat dissipation for better power handling. Aside from industry-leading excursion, these micro drivers have extremely low distortion, resulting in optimal speech intelligibility.

Motor Magnet Simulation: PMT-20N12AL04-04

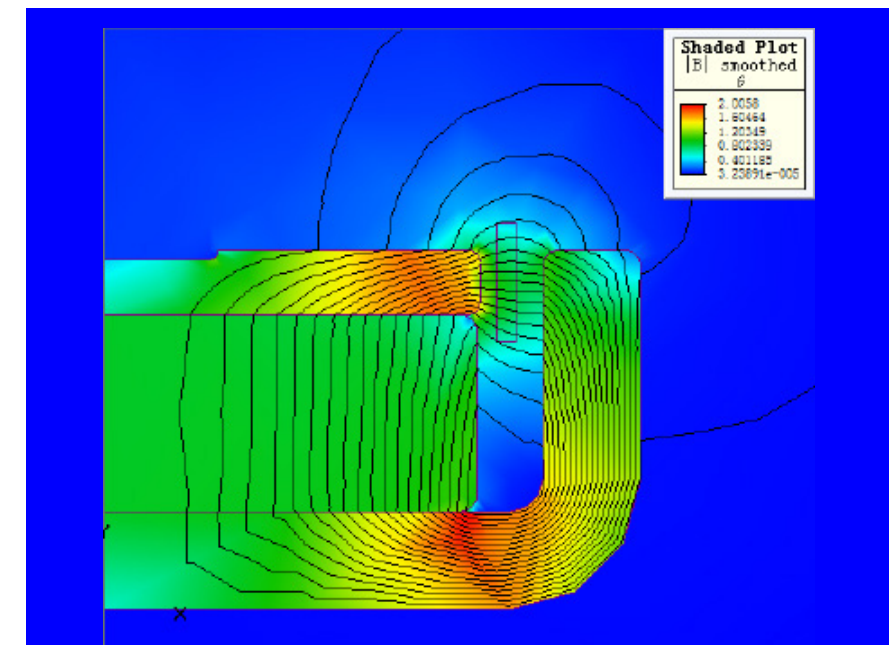

TA, TC, TG

Compact Full Range



SIZE RANGE:
1.5" - 4"



DIAPHRAGM:
ALUMINUM, PAPER,
GLASS FIBER



MOTOR:
NEODYMIUM,
FERRITE

T-Series full-range drivers come in many sizes, aspect ratios, and magnet types to address multiple performance levels and price points. This makes the T-Series a good fit for a variety of applications, ranging from compact consumer systems to teleconference systems. TC drivers have a coated paper cone, and aluminum (TA) and glass fiber (TG) options are also available. These drivers feature our PentaCut NRSC cone technology. The pro variant of the TC drivers are designed with a fabric surround, which enables higher sensitivity for professional systems.



TA, TC, TG

Technical Highlights

T-series drivers were designed to give you the flexibility to find the right performance level and price point for your application. Each driver is fully optimized to get the most out of carefully chosen, cost-effective materials.

PentaCut NRSC Cone Technology

Our patented PentaCut technology is a five-sided cut around the cone that prevents severe cone breakup and distributes cone breakup modes. By adding cuts to the cone, we are able to spread out the distortion modes, which helps us gain more control of the smoothness of the frequency response while also achieving reduced distortion.

Total Harmonic Distortion: TG9FD10-04

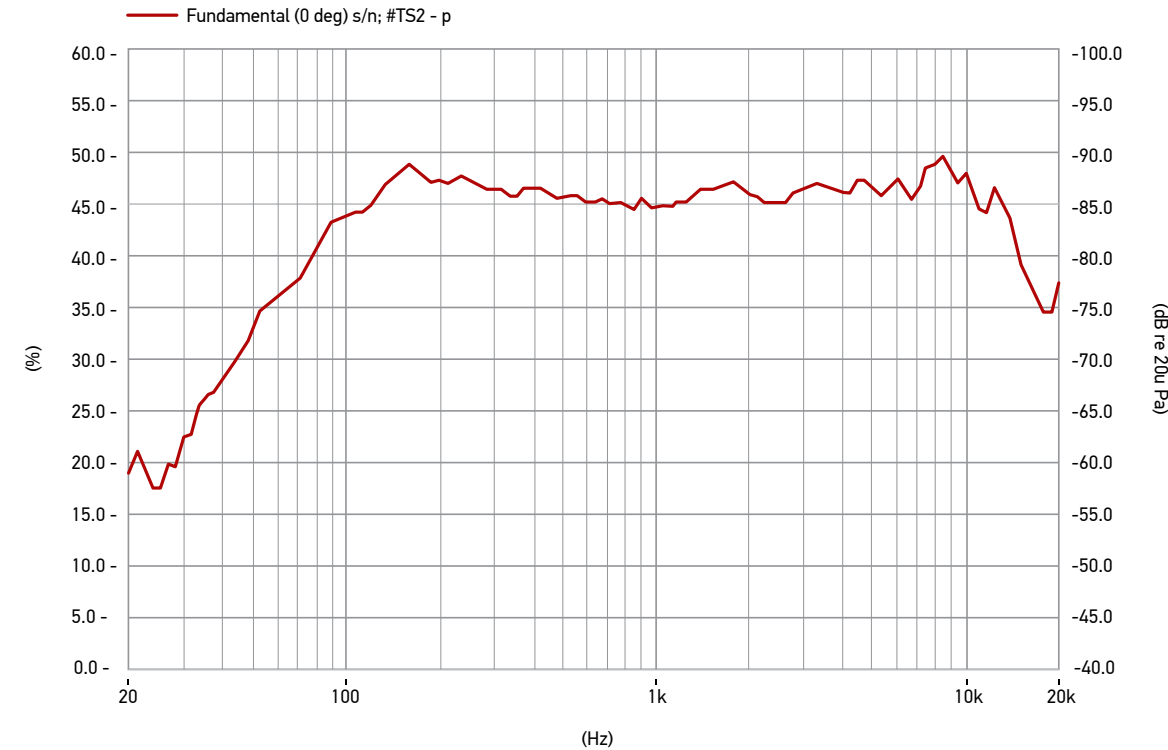

Get to know the TC5

Ranging from ultra-low-cost to ultra-high-sensitivity, the TC5 is one of the most flexible compact full-range drivers on the market. Its finely balanced design offers remarkably flat frequency response from 200Hz – 15kHz. Unique to the TC5 is a +/- 1dB SPL & sensitivity tolerance, making this an ideal driver for line array or column speakers.

Frequency & Impedance Response: TC5FC00-04

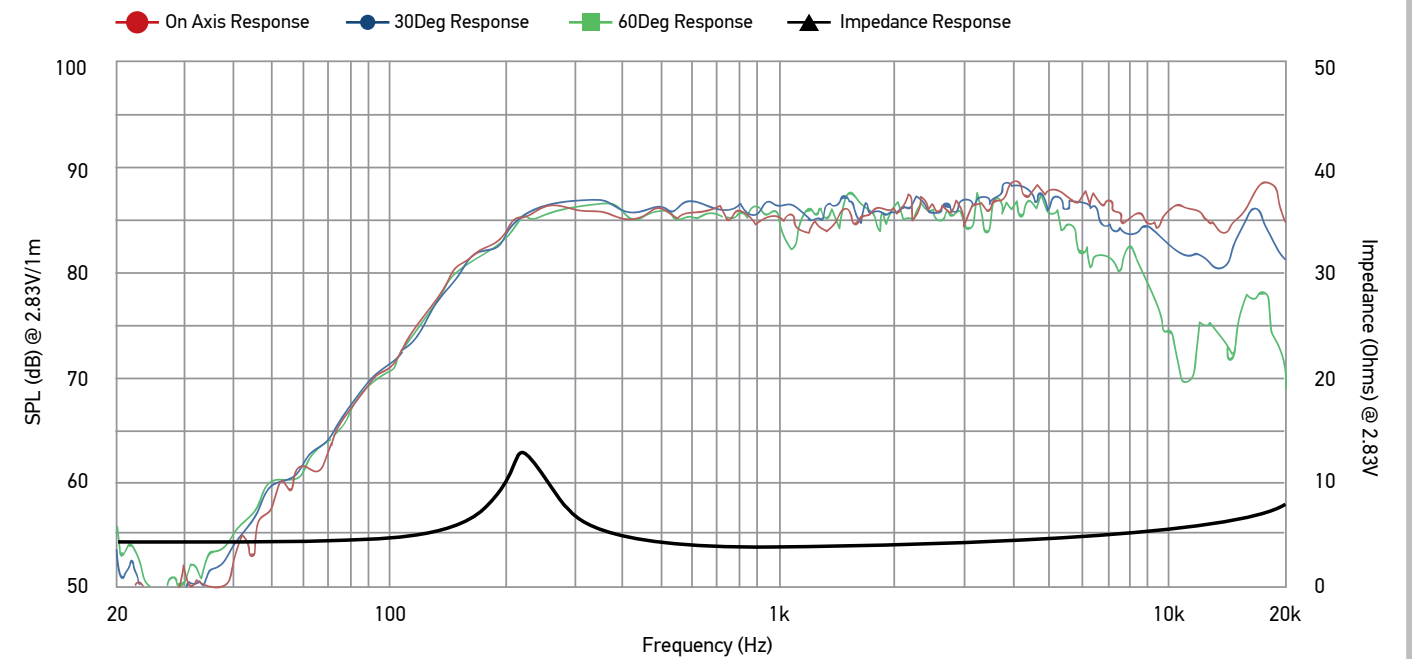

GBS

Low-Profile Woofers



SIZE RANGE:
3.5" - 10"



DIAPHRAGM:
ALUMINUM, PAPER



MOTOR:
NEODYMIUM,
FERRITE

The GBS series of woofers and subwoofers features an innovative shallow design well-suited for applications where mounting depth is scarce and low frequency performance cannot be sacrificed. High BL and moving mass and large peak-to-peak excursion enable low frequency response, even in small enclosures. This unique design allows for the same excursion in half the height of traditional woofers.



GBS

Technical Highlights

With GBS, our goal was to reduce the overall height of the woofer, while still allowing large excursions of the diaphragm. There are two key features that make this possible:

- The geometry of the diaphragm is dome-shaped, rather than cone-shaped – this allows the motor to be raised, taking advantage of the space underneath the dome, and reduces the total height significantly.
- Raising the motor normally would not be possible, due to placement of the spider. The solution is to invert the spider fixation arrangement, which allows for a secondary suspension that doesn't interfere with the new motor location.

Height-Saving Comparison

GBS Profile vs. Conventional Woofer Profile

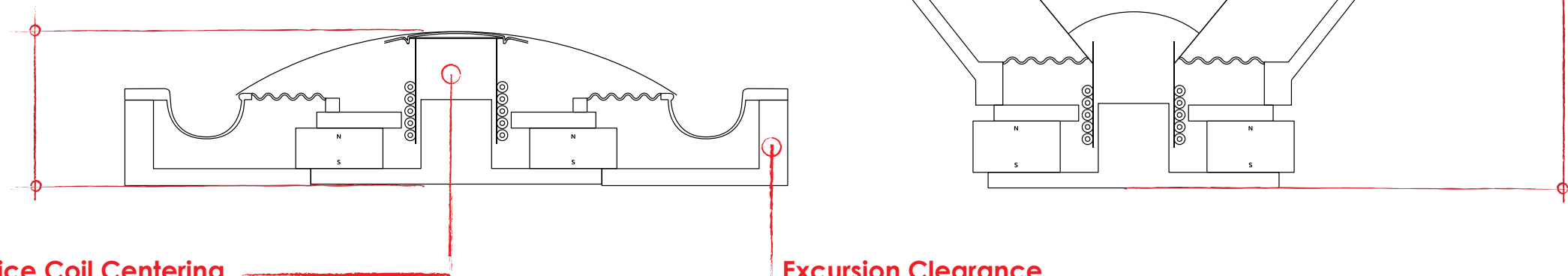

Voice Coil Centering

The centering of the voice coil in the magnetic gap is provided by both the surround and spider. With the use of FEA, we designed lateral stability into the suspension system, which helps to control the rocking modes and allows a reduction of distance between both suspensions. The dome geometry of the diaphragm assists with mass centralization – as a result, the rocking mode center of the driver is placed in a similar plane as the voice coil and magnetic gap. Thus, the driver has a much higher tolerance to rocking modes than a conventional driver, which has a pendulum-like relationship between the voice coil and suspension.

Excursion Clearance

Both the basket and suspension components were carefully designed to allow full excursion, without risk of rocking or hard "bottoming". All mechanical excursion clearances were precisely balanced to ensure that the driver is of the minimum height for a given excursion capability.

HDS

Hi-Fi Woofers



SIZE RANGE:
4" - 8"



DIAPHRAGM:
MULTIPLE OPTIONS



MOTOR: FERRITE

The HDS family stays true to its Peerless heritage with enhanced performance. HDS drivers feature cast aluminum frames and ferrite magnets. Multiple cone materials are available for unique visual and acoustic characteristics. These drivers are designed with under-spider venting and shorting rings to lower distortion. The HDS series is designed with performance in mind for consumer and Hi-Fi applications.



NE

Woofers, Subwoofers, Full Range



SIZE RANGE:
2" - 12"



DIAPHRAGM:
ALUMINUM,
WOOD FIBER



MOTOR:
NEODYMIUM

The NE family draws on over 80 years of Vifa heritage. NE woofers, subwoofers, and full-range transducers feature our patented PentaCut Cone technology and are designed with premium components to meet specs suitable for Hi-Fi applications. They feature stylish cast aluminum frames coupled to the motor for heatsinking and increased power handling.



SBS

Woofers, Subwoofers, & Passive Radiators



SIZE RANGE:
6" - 12"



DIAPHRAGM:
ALUMINUM, PAPER



MOTOR: FERRITE

SBS drivers are designed to be a great value and are a popular choice for a variety of consumer audio systems. The SBS family was designed with high excursion in mind, and passive radiators are available at each size for flexibility in designing systems with great low frequency performance. The unique basket design prevents finger probes from entering the product enclosure, and is intended to satisfy standard UL 60065.



SDF

Woofers, Subwoofers



SIZE RANGE:
10" - 15"



DIAPHRAGM:
PAPER



MOTOR: FERRITE

The SDF series are high-performance woofers and subwoofers designed for more bass in smaller-than-traditional enclosures. These drivers were designed with a 3" voice coil and a robust ferrite magnet system, which enables higher power handling, enhanced low-end response, and more linearity. The newly designed aluminum frame is built for extra rigidity and heat dissipation with a vented paper cone for reduced air compression. These woofers are built for high-performance, high-excursion consumer and Hi-Fi applications.



SDS

Woofers, Subwoofers, & Passive Radiators



SIZE RANGE:
4" - 6.5"



DIAPHRAGM:
PAPER



MOTOR: FERRITE

The SDS series is an affordable family of mid-sized drivers. They feature low-resonant frequencies and are ideally suited for compact, sealed enclosures. Passive radiators are available in 4" and 5.25" and are designed to be mated with an active SDS driver.



SLS

Woofers & Subwoofers



SIZE RANGE:
3.5" - 12"



DIAPHRAGM:
PAPER



MOTOR: FERRITE

The SLS family is built upon the foundation of the SDS line, but engineered for higher performance. A ferrite motor with an aluminum shorting ring is used to lower distortion. SLS drivers are available in many sizes and are a great fit for consumer audio systems.



STW

Subwoofers



SIZE:
15"



DIAPHRAGM:
FIBER-REINFORCED
PAPER



MOTOR: FERRITE

The STW series of subwoofers was designed with performance and space in mind. These drivers offer deep and clean low frequency reproduction with minimal distortion at high sound pressure levels. STW Drivers can be mounted in a much smaller box than traditional subwoofers, which is enabled by the high-moving mass and 8" voice coil. Each subwoofer also features an FEA-optimized ferrite motor for extremely low power compression.

[Return to Table of Contents](#)



STW

Technical Highlights

STW subwoofers were designed to provide optimal bass performance in an enclosure that is much smaller than a traditional design. These drivers were developed with a triple suspension and dual spiders for low distortion, high-moving mass, and a large voice coil — enabling high peak-to-peak displacement.

Benefits of a Large Voice Coil

With a small enclosure design, high-moving mass is necessary, but it needs to be applied where it can be put to work. With STW, it was put into the voice coil – this improves the performance of the driver by raising the motor force factor. Unlike a conventional motor design, B_l changes very slowly as a function of voice coil displacement. A voice coil with large surface area offers another benefit – power compression is practically non-existent. Because of this, the voice coil takes longer to heat up, resulting in uncompressed dynamic musical peaks.

More Efficient Motor Design

We were able to achieve more efficient use of the ferrite magnet by putting it inside the voice coil. Motor structures with the magnet outside of the motor lose 50% of their energy in stray fields, while a magnet on the inside of the voice coil will have 90% or better magnet utilization.

Magnet Simulation: STW-350F188PR01-04

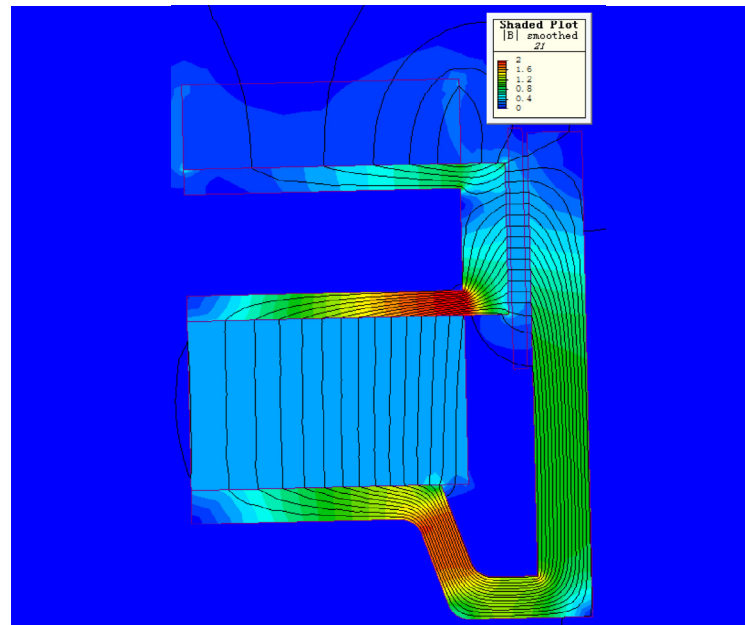

In-Box Simulation

60cm x 60cm x 60cm Enclosure

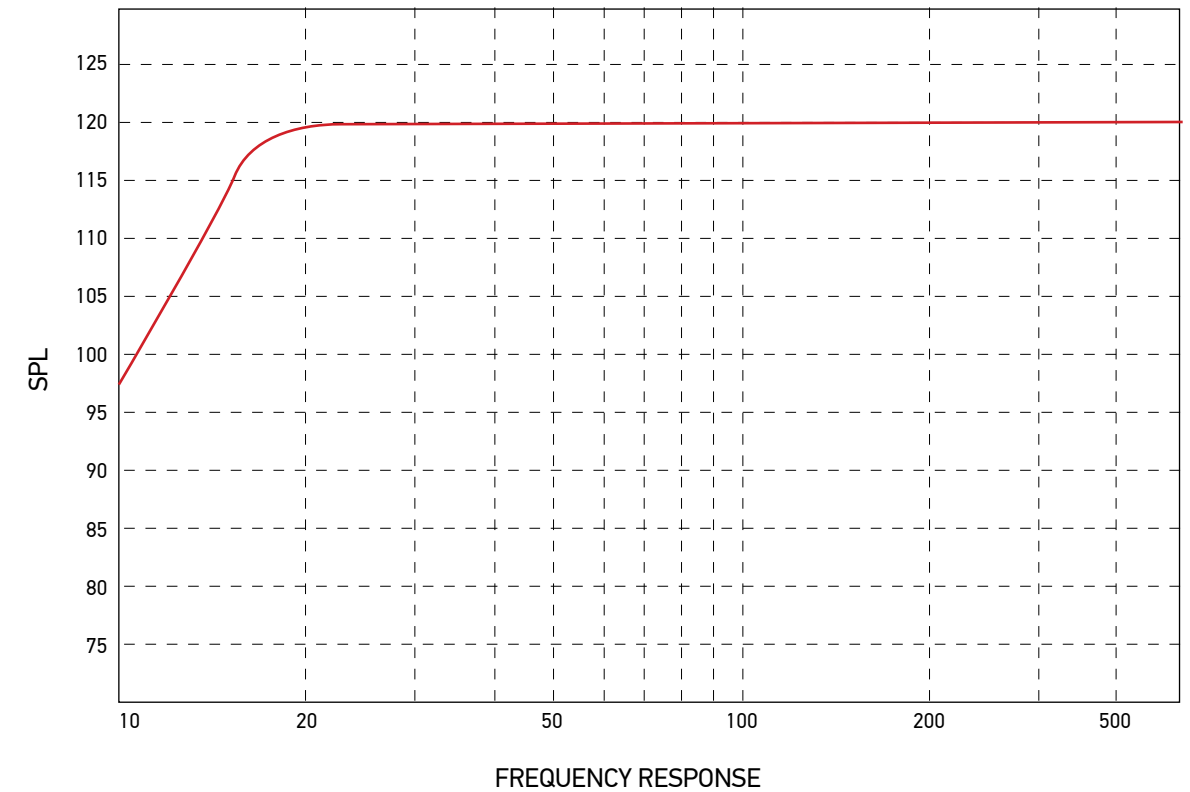

XLS & XXLS

Subwoofers



SIZE RANGE:
10" & 12"



DIAPHRAGM:
PAPER, ALUMINUM,
FABRIC



MOTOR:
DOUBLE FERRITE

The XLS and XXLS families of subwoofers are equally suited for consumer and demanding studio applications. Designed for industry-leading extended excursion, they have set the subwoofer benchmark for over a decade. Several models use coated paper cones, with aluminum and engineered cellulose fiber models also available. High power handling and reliability are achieved with high-quality components and extensive testing.

[Return to Table of Contents](#)



BC

Tweeters



SIZE RANGE:
19mm – 25mm



DIAPHRAGM:
FABRIC



MOTOR:
NEODYMIUM,
FERRITE

BC tweeters feature damped fabric domes and ferrofluid-filled motors for improved cooling and power handling. All models have an included faceplate. The family is a good all-around tweeter for a variety of consumer applications, and we also offer these tweeters with increased sensitivity for professional systems.



D, DA, DQ, DX

Tweeters



SIZE RANGE:
19mm – 25mm



DIAPHRAGM:
SILK, ALUMINUM,
TITANIUM



MOTOR:
NEODYMIUM,
FERRITE

The D Series is designed with a variety of diaphragm materials: silk (D, DX), aluminum (DA), and titanium (DQ). Models are available with ferrofluid-filled neodymium or ferrite motors and faceplates in multiple configurations. With many variations available, these tweeters are a great fit for a variety of consumer and Hi-Fi applications.



DA

Technical Highlights

DA Series tweeters are designed for both Hi-Fi and professional applications. With their unique material and design enhancements, these tweeters are built for industry-leading performance and reliability.

Magnet Simulation: DA32TX00-08

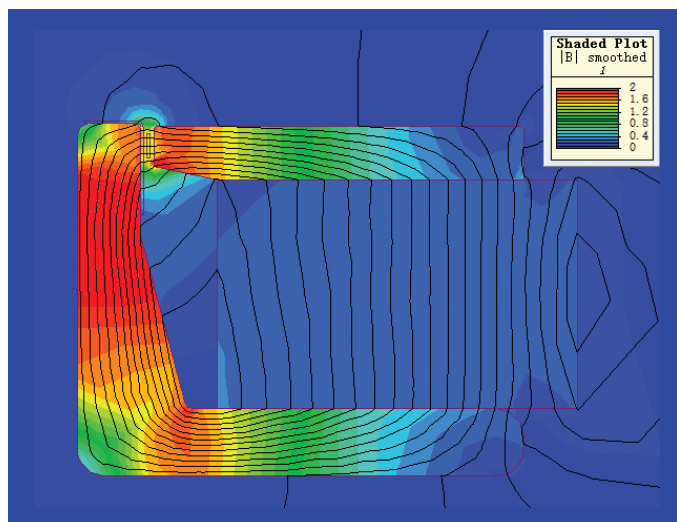

Fully Optimized Materials

The DA25TX and DA32TX are built with a corundum dome. This unique material offers extreme rigidity and excellent damping, which enables an unmatched usable bandwidth. The deep rear chamber provides extended low frequency response, while the larger magnet and high Xmax allow high output, even at low frequencies.

Design Enhancements

The DA32 and DA25 were designed without a phase plug or any other obstruction in front of the dome. This enables a much smoother off-axis response than competitive drivers. Additionally, the flat faceplate gives these tweeters a very wide dispersion.

Both the DA25TX (25mm) and DA32TX (32mm) offer low Fs and very high linear Xmax, achieved with a longer voice coil and bigger magnetic gap. What really sets these tweeters apart from the competition is the incredibly low recommended crossover points:

DA25TX – 1.3 kHz

DA32TX – 1.1 kHz

Frequency & Impedance Response: DA25TX00-08

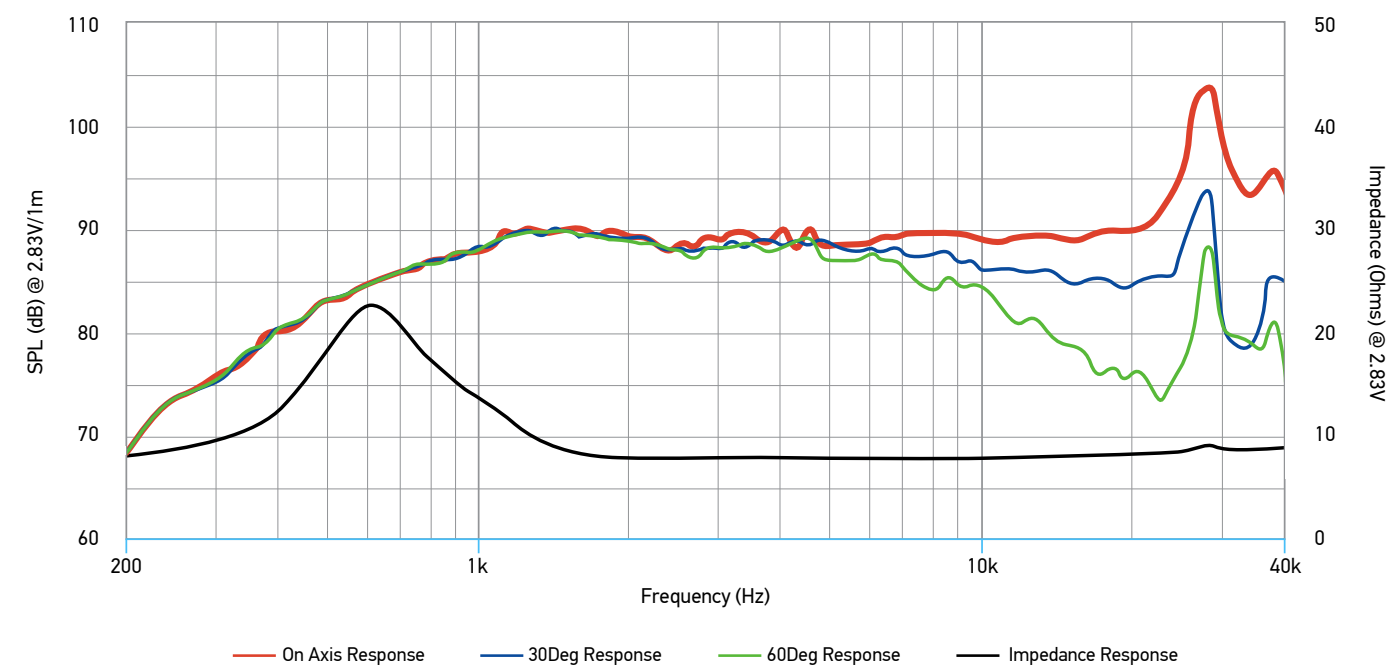

H

Horn Tweeters



SIZE:
25mm



DIAPHRAGM:
SILK, TITANIUM



MOTOR: FERRITE

The H-Series of tweeters include a ferrofluid-filled motor and a compact horn integrated with the faceplate. The drivers are designed with ultra-high sensitivity, and a large motor for robust power handling capacity. These features make the H-Series a good fit for professional and consumer applications alike.



NE

Hi-Fi Tweeters



SIZE RANGE:
19mm & 25mm



DIAPHRAGM:
FABRIC



MOTOR:
NEODYMIUM

Designed with cutting-edge technology in a stylish design, NE tweeters are ideal for Hi-Fi applications. They feature fabric diaphragms and an aluminum faceplate with integral finger protection, providing protection for the diaphragm. The neodymium motor with copper cap provides lower coil inductance and distortion. An aluminum rear chamber contributes to extended low frequency response and doubles as a heatsink.

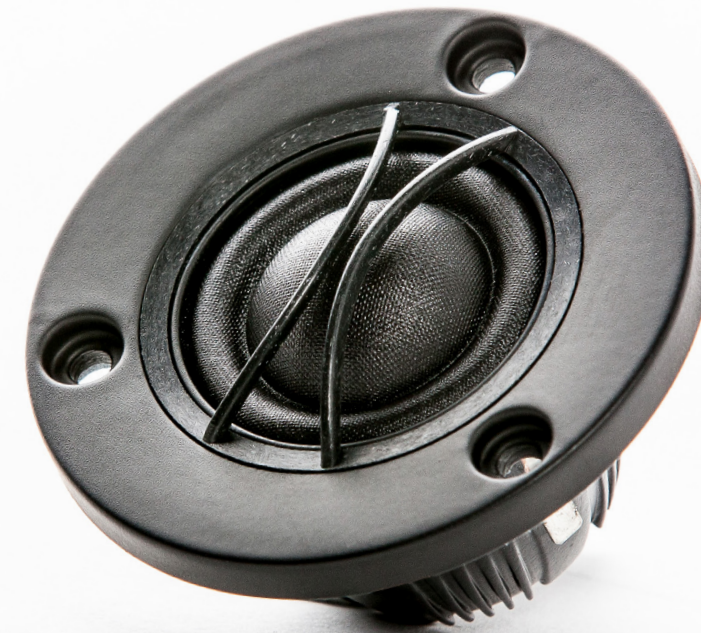

[Return to Table of Contents](#)

OC, OX, & OT

Compact Tweeters



SIZE RANGE:
16mm, 19mm,
& 25mm



DIAPHRAGM:
FABRIC, SILK



MOTOR:
NEODYMIUM

With compact neodymium motors, rear chambers, and no faceplates, these tweeters are designed to fit into small spaces. OC tweeters feature a damped fabric dome and a twist-lock mechanism built into the frame, allowing easy installation in custom faceplates. OX models feature a damped silk diaphragm and large surround roll. OT models feature our patented ring radiator and central waveguide technologies.



XT

Ring Radiator Tweeters



SIZE RANGE:
19mm, 25mm



DIAPHRAGM:
FABRIC



MOTOR:
NEODYMIUM,
FERRITE

The XT series of tweeters feature Tymphany's patented ring radiator and central waveguide technologies, delivering exceptional sound quality. A rear chamber provides extended low frequency response. A faceplate is included on most models and is available in multiple configurations. The XT series is well-suited for Hi-Fi applications.



FSL

Professional Loudspeakers



SIZE RANGE:
5" - 18"



DIAPHRAGM:
PAPER



MOTOR:
FERRITE

The FSL series of pressed frame low-frequency drivers deliver on our vision to offer more value than its competitors. It has been designed to provide more power handling, higher sensitivity, lower F_s , and a smoother frequency response.



FSL

Technical Highlights

FSL loudspeakers are designed for higher performance at a lower price point. Unlike many drivers in this category, these drivers go through the complete optimization process – Suspension, BL, Klippel Analysis, Thermal Behavior – and full validation testing, ensuring the best performance and reliability.

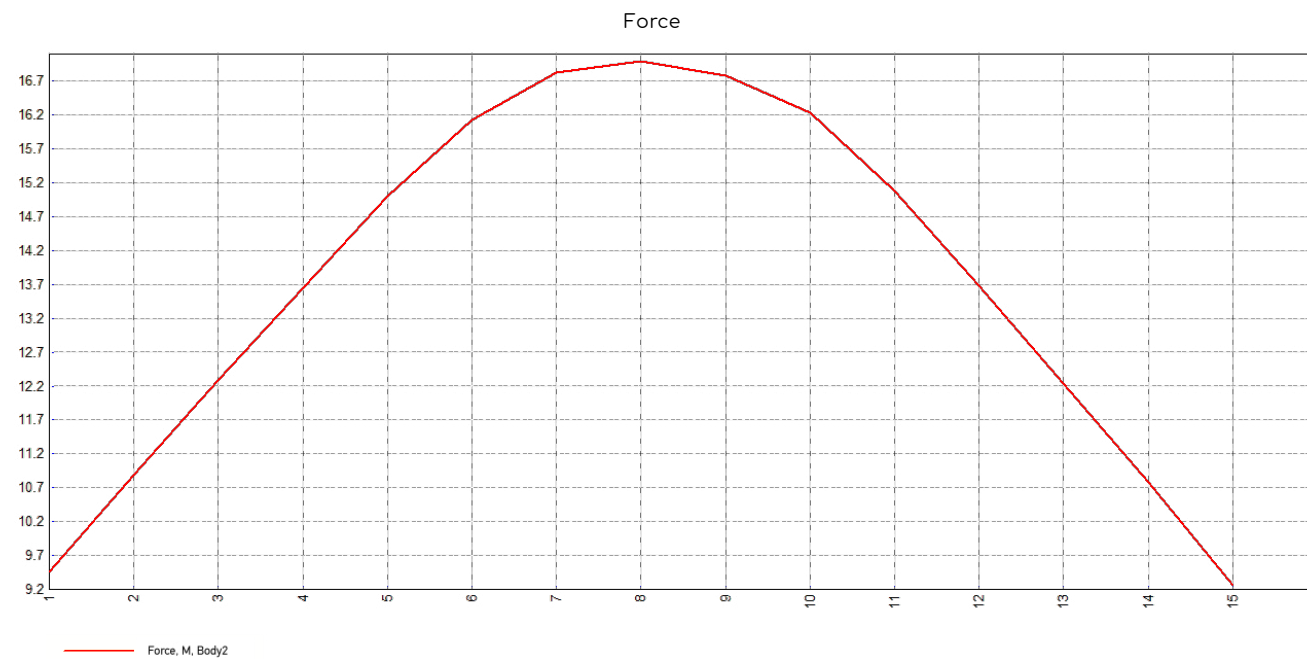

Wide Selection of Designs

The FSL woofer features a ferrite magnet, pressed steel basket, paper diaphragm, and fabric surround. A wide selection of chassis sizes from 5"-18" will meet your specific design needs.

Peerless Product Model	Chassis Size	Voice Coil Diameter	Power Handling (AES)	Sensitivity 1W/1m	Resonance Frequency	Rated Impedance
FSL-1020R03-08	10 in	2.0 in	200w	93.4 dB	49Hz	8 Ω
FSL-1225R02-08	12 in	2.5 in	230w	97.0 dB	59Hz	8 Ω
FSL-1530R01-08	15 in	3.0 in	350w	98.0 dB	41Hz	8 Ω
FSL-1830R09-08	18 in	3.0 in	600w	94.6 dB	33Hz	8 Ω

NOTE: This is a selected sample of the FSL range.

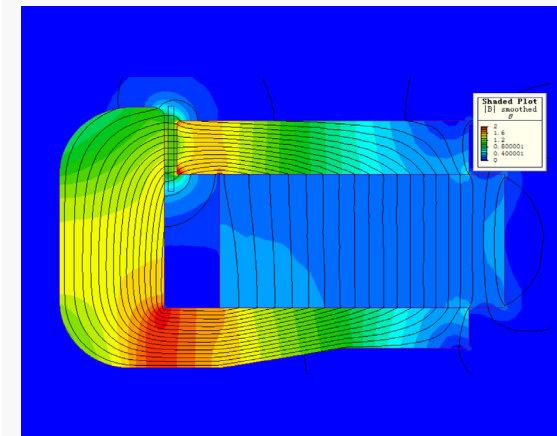

Magnet FEA

FSL-1225R02-08

With all Peerless drivers, we use FEA simulation on every motor system design to maximize flux density and optimize BL symmetry. The result is an efficient and cost-competitive solution for your system.

NCP

High-Performance Professional Loudspeakers



SIZE RANGE:
12", 15" WITH MORE
COMING SOON



DIAPHRAGM:
FIBER-REINFORCED
PAPER



MOTOR:
NEODYMIUM

The NCP series is our line of premium professional loudspeakers. No detail was overlooked to create a new industry standard: cone optimized through Klippel scanning vibrometer testing and Klippel power tested. Class-leading power handling is achieved with a new forced convection cooling system to reduce power compression for higher output levels.



NCP

Technical Highlights

Professional sound applications demand quality sound, performance, and reliability. Our NCP loudspeakers were designed to meet those demands through innovative features, such as the forced convection cooling system, and premium materials carefully selected to achieve the best cost/performance possible.

Forced Convection Cooling System

With NCP, we designed the frame with cast aluminum to help conduct heat away from the motor. In addition, we added specially positioned air vents to direct air past the motor and into/through the heatsink. The heatsink also utilizes aluminum fins, specifically arranged to dissipate heat when the driver is mounted in a conventional, front-facing orientation. The result of this system is high power handling with extremely low power compression.

Air Flow Chart

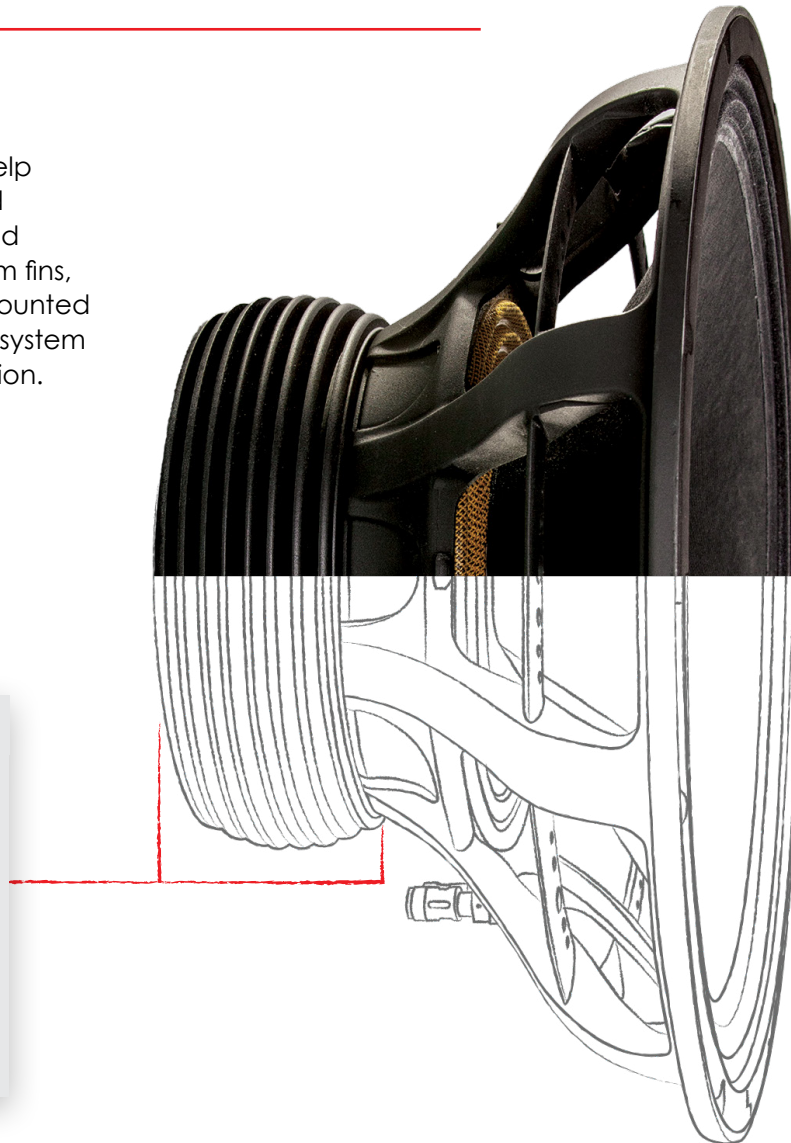
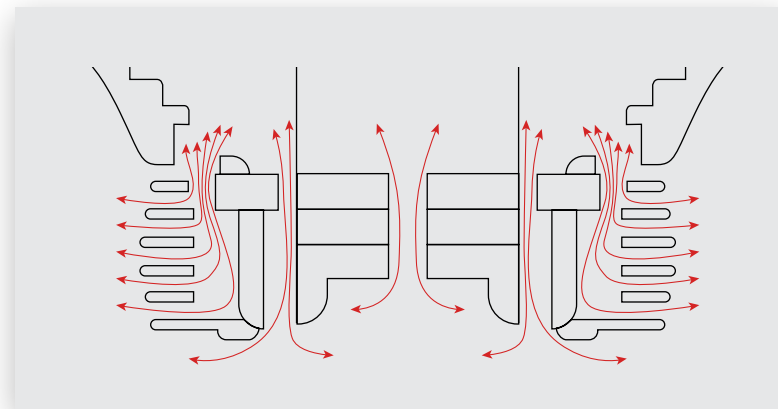

FEA-optimized Neodymium Magnet

Neodymium is lighter and stronger than ferrite, so the loudspeaker's weight is about half of an equivalent performance woofer made with a ferrite magnet. With the help of FEA (finite element analysis), we optimized the driver to have the best balance of weight (minimized), performance (magnetic flux density in the airgap is maximized, fringe flux is symmetrical), and cost (minimized).

Magnet Simulation: NCP-1230R01-08

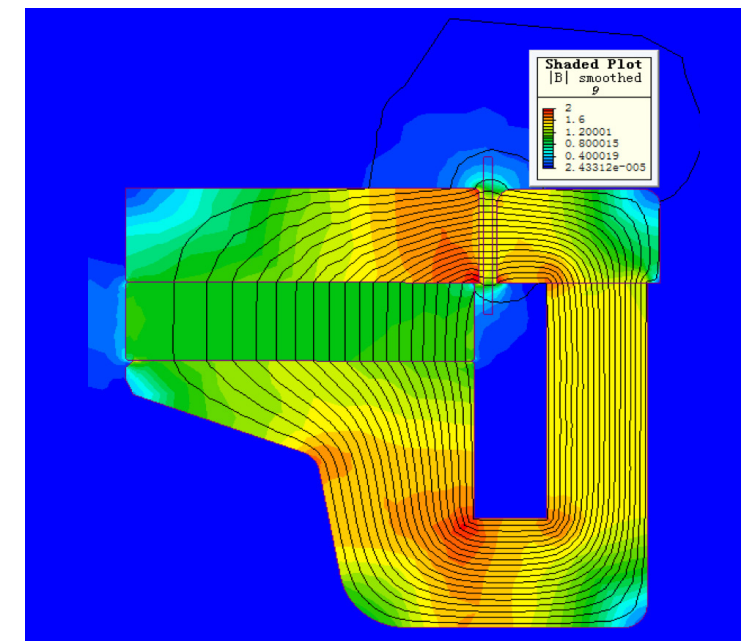

DFL, DFM

High-Frequency Compression



SIZE RANGE:
DFM: 1" EXIT, 1.4" VC
DFL: 1" EXIT, 1" VC



DIAPHRAGM:
PURE TITANIUM FOIL
HIGH-TEMP.
SYNTHETICS



MOTOR: FERRITE

Our series of compression drivers are designed for use in high-quality sound reinforcement systems. The polyimide surround allows for reliable operation in 2-way systems with lower crossover points, while the titanium diaphragm is coated with a light, thin layer of unique damping material, which gives the drivers an unusually smooth sound.



COMPRESSION DRIVERS

Technical Highlights

Our growing lineup of high frequency compression drivers are best suited for professional sound-reinforcement applications. Built for their reliability and high output, these drivers are meant for large audiences. Our DFM-2535 is no different – we use environmental-resistant materials (heat, vibration, aging), to ensure years of stable performance.

With the DFM-2535, we were able to achieve a crossover point at 1.5kHz, while most competitive models on the market are at 2.5kHz or higher. This is enabled by both material and design enhancements:

1. Unlike other compression drivers on the market, the DFM-2535 utilizes a separate kapton surround – the softer suspension and high-temperature, well-damped surround enables the lower F_s .

2. We also use a heat conduction path from the coil to the dome, rather than using thermally insulated material. This allows the driver to conduct heat from the coil to the dome and radiate it.

Phase Plug Analysis – DFM-2535

One function of the phase plug is to ensure the pressure waves coming out of the exit are flat. These flat pressure lines indicate that soundwave path lengths from driver to the listener are equalized. These critical dimensions can make or break a compression driver's performance. Our drivers are fine-tuned by FEA and subjective listening tests to ensure optimum performance.

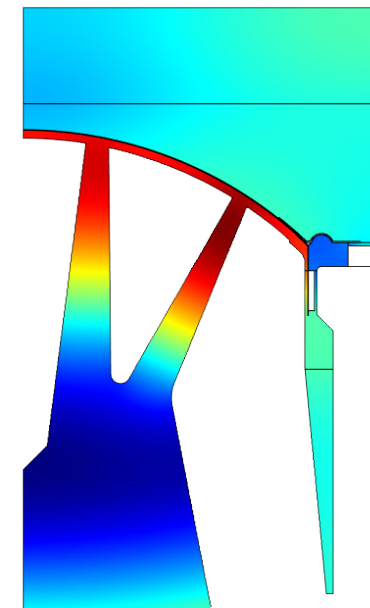
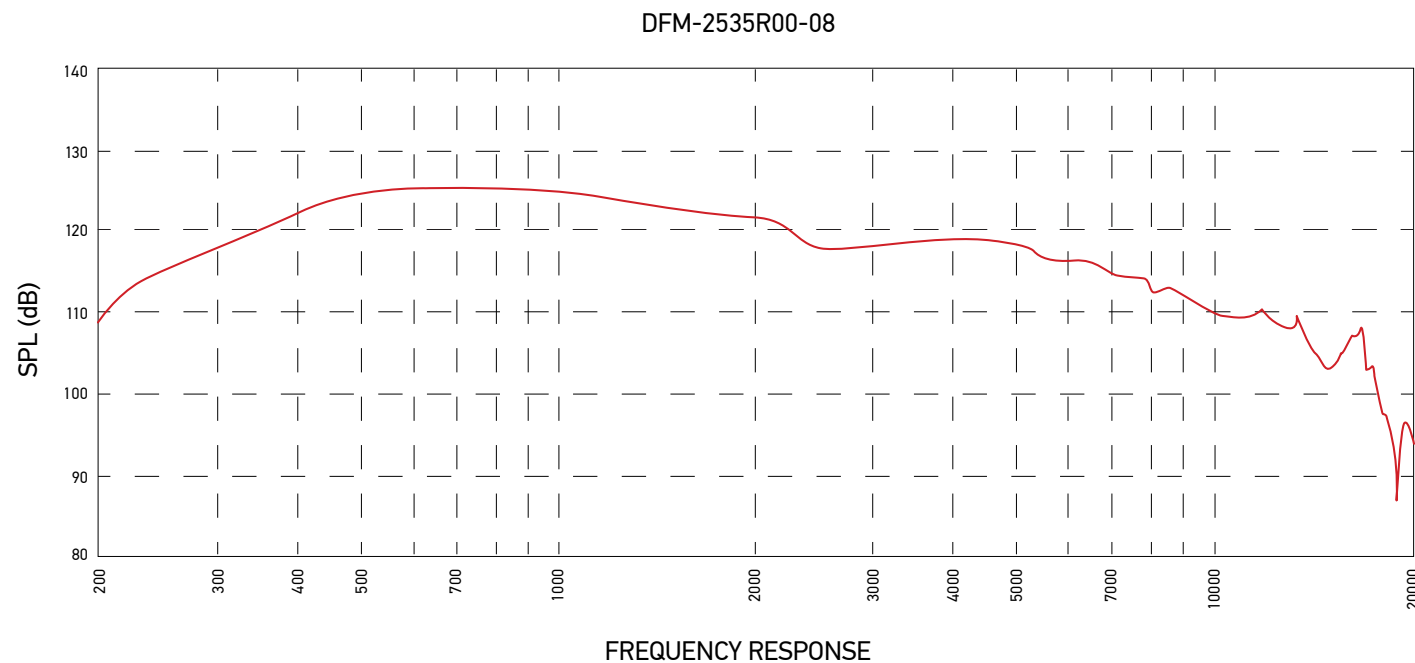

2D View

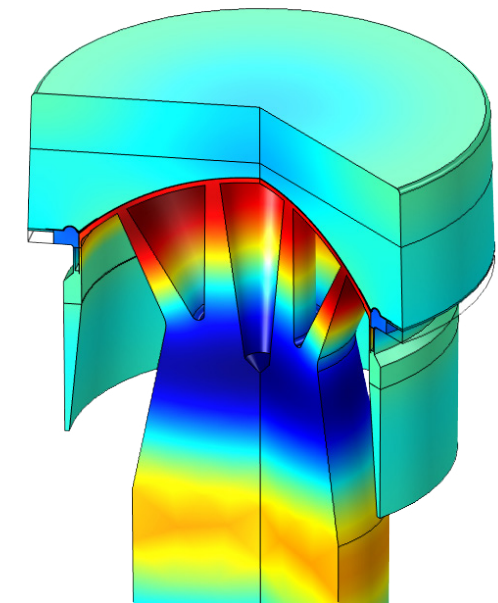

3D View

LCPF

Peerless Pro Family of Power Amplifier Modules



POWER RANGE:
600W – 1200W



POWER SUPPLY:
RESONANT LLC –
ACTIVE PFC



CONFIGURATIONS:
FLEXIBLE 2 – 4
CHANNELS

For nearly a decade, Peerless has been driving innovation and working with the most respected names in the pro industry. We now bring that extensive experience and our system design mindset to our new electronics module. The LCPF family is Peerless's line of flexible and reliable professional power amplification modules.

Our efforts are not just about the module. They are about enabling your teams to design the best end product that stands out with the performance, features, and competitiveness to help you win in the market.

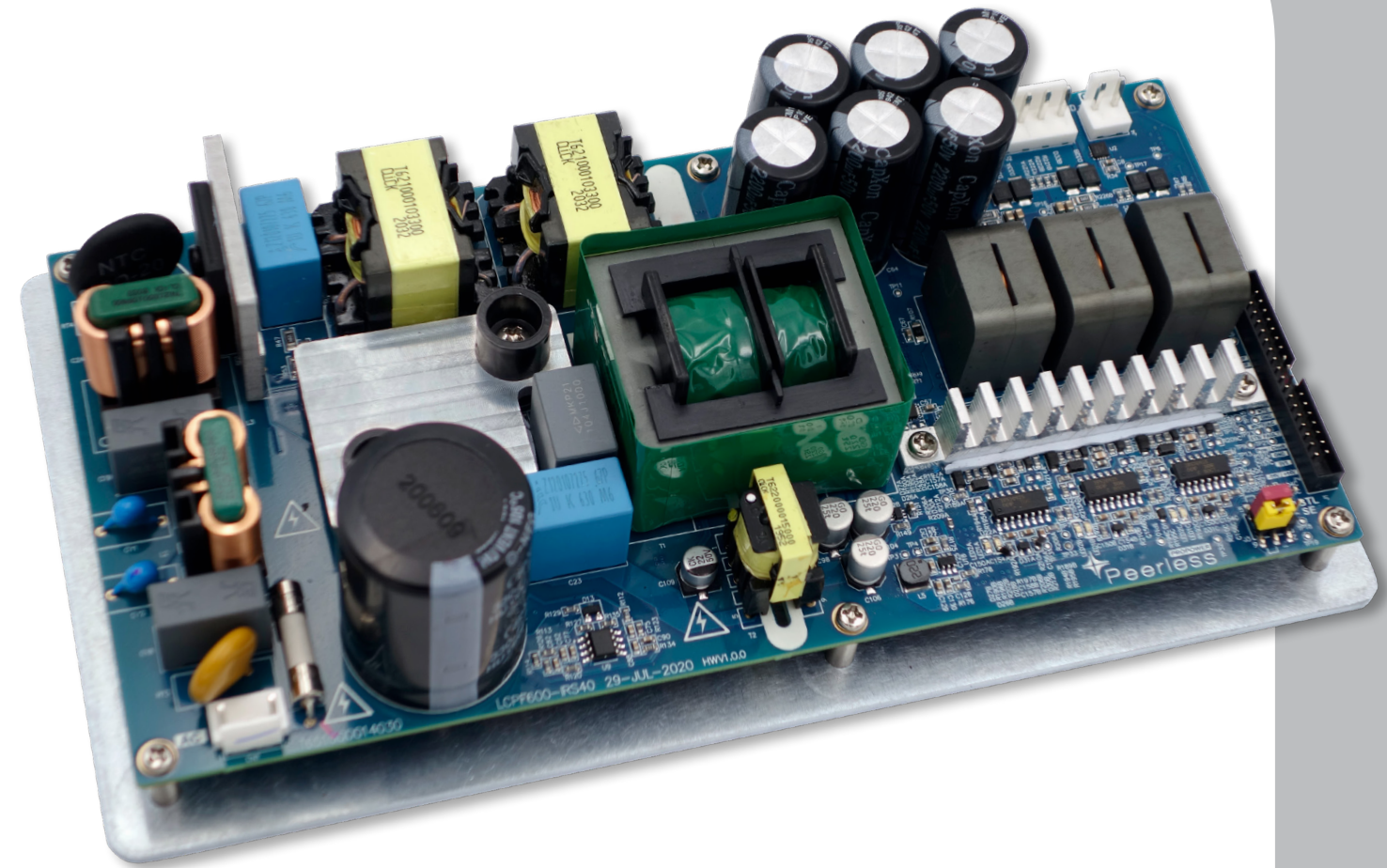

LCPF

Technical Highlights

The LCPF family of amplifier modules introduces a robust power supply, extensive monitoring facilities, and output configuration flexibility for your pro system design needs.

Optimized Power Supply Driving Performance

The LCPF amplifier modules contain an interleaved PFC which brings low and optimal current draw from the mains supply and avoids the need for multiple voltage versions of products. PFC also improves performance when a system is being run off a current-limited supply. The second stage of the SMPS design, the LLC converter, provides well-regulated and low-noise voltage rails with an absence of mains ripple.

Finally, our integrated power supply is optimized for continuous and peak output. Our designs are named after our power supply ratings in the most demanding use case (low mains voltage, low frequency). No bad surprise, no inflated numbers.

Efficiency vs. Loading Power

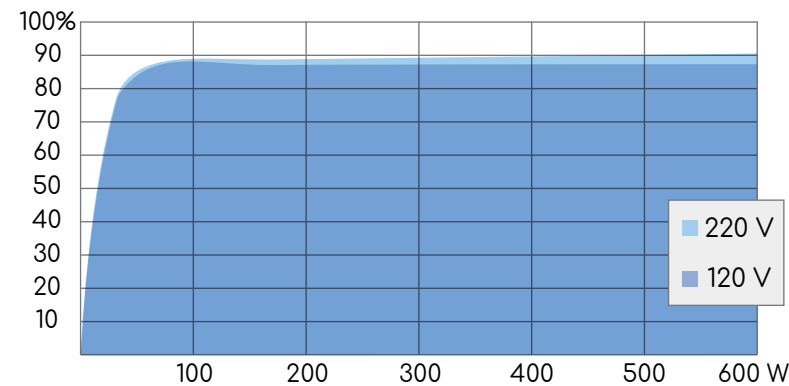

Monitoring to Improve System Performance With DSP

Extensive monitoring is included — for each amplifier stage, the output current and voltage are continuously reported back to the front-end board for analysis, reaction, and performance optimization. Amplifier and power supply temperatures are also continuously reported so appropriate measures can be taken to protect the system in extreme thermal conditions.

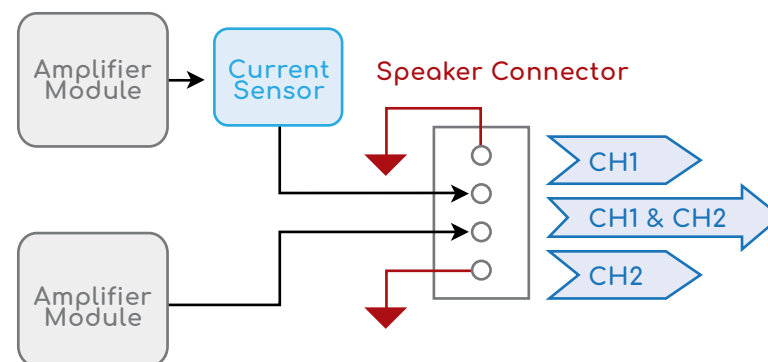

LCPF600 Power Amplifier Module Block Diagram

Flexible Channel Configuration With Systems In Mind

As the output channels can be run as single-ended (SE) or bridge-tied-load (BTL), multiple channel configurations are possible, allowing you to create many different systems from our standard modules. Additionally, they can be built into rack amplifiers, offering a great variety of output power configurations.

Example Configurations

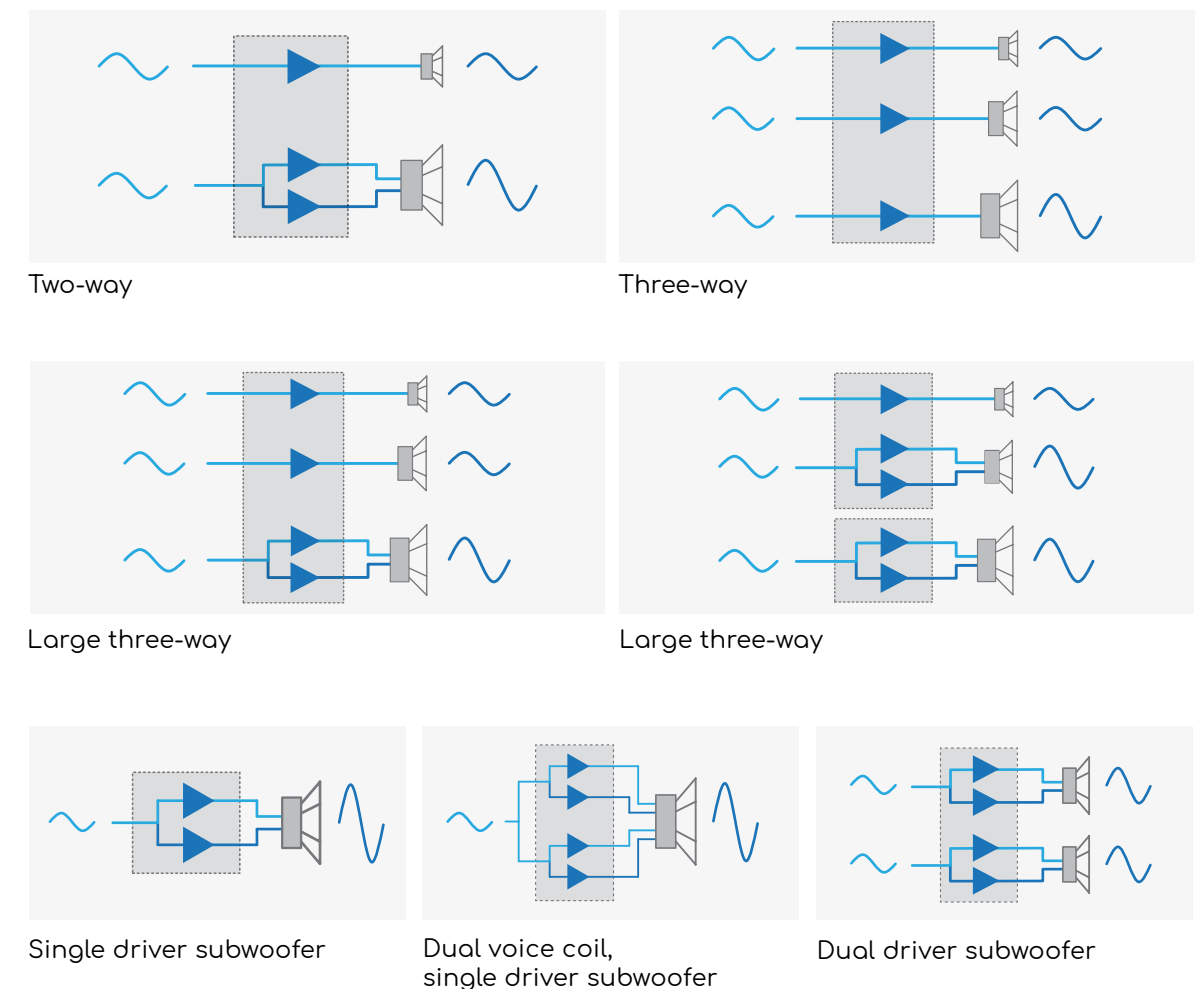

HPD & HRD

Headphone

SIZE RANGE:
40mm, 50mm, 60mm

DIAPHRAGM:
POLYMER, PAPER

MOTOR:
NEODYMIUM

Our series of headphone drivers is designed for both over-ear and on-ear platforms. Along with their high sensitivity and low THD, these drivers offer extended high frequency response, optimal clarity, and smooth bass performance. Standard dome, ring radiator, and dual-concentric designs available.



[Return to Table of Contents](#)

ANC

Conferencing and Telecommunications



SIZE:
2"



DIAPHRAGM:
ALUMINUM



MOTOR:
NEODYMIUM

These compact, full-range drivers are built from the ground up for telecommunications and conferencing applications. They are optimized for low THD, off-axis response, and clarity throughout the voice band. This enables telecommunications systems with advanced echo cancellation algorithms, 360° sound, and voice intelligibility.



ANC

Technical Highlights

ANC drivers are designed specifically for conferencing applications. Voice is reproduced clearly to stand out, and distortion is minimized to work well with acoustic echo cancellation algorithms. The power response is smooth for easy EQ and extends into the ultrasonic range for potential pairing applications. Plus, their shallow and compact size integrates easily into small form factors.

Response Optimized for Voice

The ANC family of drivers is best suited to voice reproduction while also adeptly handling music. A smooth frequency response allows easy equalization for the designer. An aluminum cone increases sensitivity, brings the break-up mode above the vocal range, and extends high frequency output into the ultrasonic region (pairing applications).

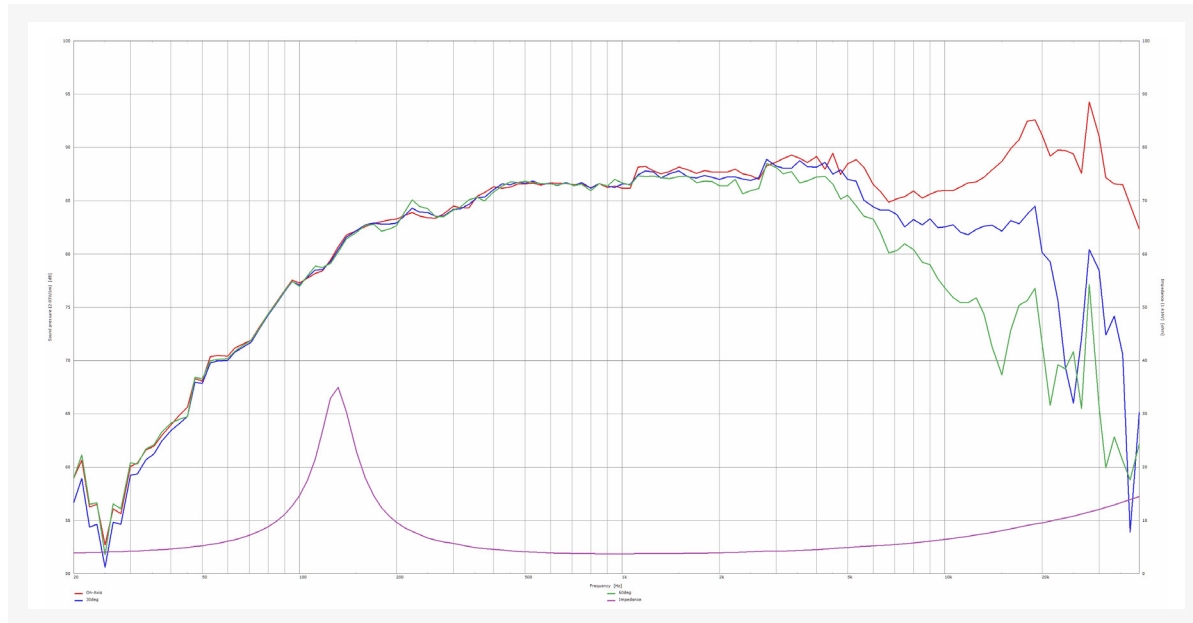

A smooth power response (off-axis) (see blue and green curves above) guarantees an evenly distributed sound in the room where multiple people might be listening.

Low Distortion by Design Helps Your Algorithms

For telecommunications and conferencing applications, low distortion in driver design is critical. Acoustic echo cancellation algorithms work best when the transducer is completely linear so that all sounds are predictable. The large signal measurements shown below demonstrate the extra care taken to design a symmetrical driver while also extending the linear working range to that not typically seen in drivers of similar size and depth. Together, they allow lower-than-average harmonic distortion.

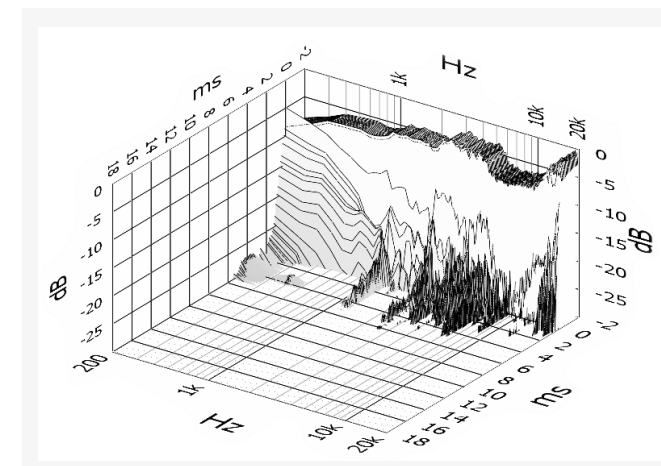
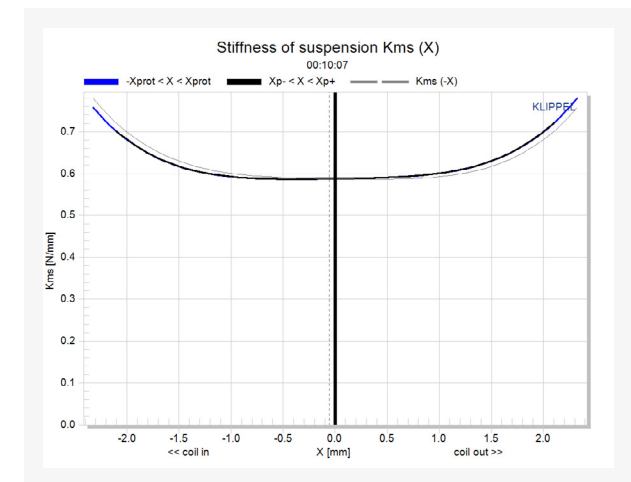
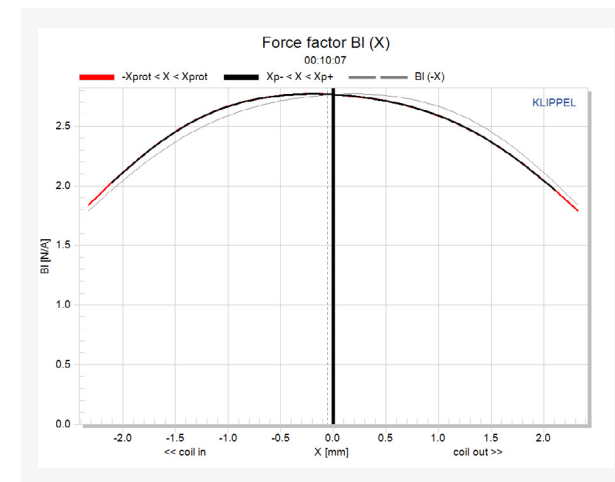

No strong resonances in the waterfall plot indicate a tight time domain behavior, ensuring that the driver provides clean, predictable output.

PEERLESS SOLUTIONS

Empowering Innovation | Easy Integration | Greater Reliability



Contact us: tympany.com/contact
For our distribution partner list:
tympany.com/contact/find-a-distributor

PEERLESS BY TYMPHANY

TYMPHANY ACOUSTIC TECHNOLOGY LTD. UK | UNIT 12 HORSEFAIR RD. | WATERTON INDUSTRIAL ESTATE | BRIDGEND, CF31 3YN

